

Date: February 07, 2025**The Manager, DCS
The Bombay Stock Exchange Ltd.**
Phiroze jeejeebhoy Towers,
Dalal Street,
Mumbai**The Manager
National Stock Exchange of India Ltd.**
Exchange Plaza, C-1, Block G,
Bandra Kurla Complex,
Bandra (E), Mumbai – 400 051**Ref: Scrip Code: - 530655****Scrip Code: - GOODLUCK****Dear Sir/Madam,****SUB: Investor Presentation for Q3 and 9 M FY 2025**

Dear Sir,

Pursuant to the regulation 30 of the SEBI (Listing Obligations and Disclosure Requirements) Regulations, 2015 a copy of the Investor's Presentation for Q3 and 9M FY 2025 of the Company is being enclosed herewith.

This is for your information and doing the needful.

For GOODLUCK INDIA LIMITED**RAMESH CHANDRA GARG
DIRECTOR****Encl: as above**



WWW.GOODLUCKINDIA.COM

GOODLUCK INDIA LIMITED

INVESTOR PRESENTATION

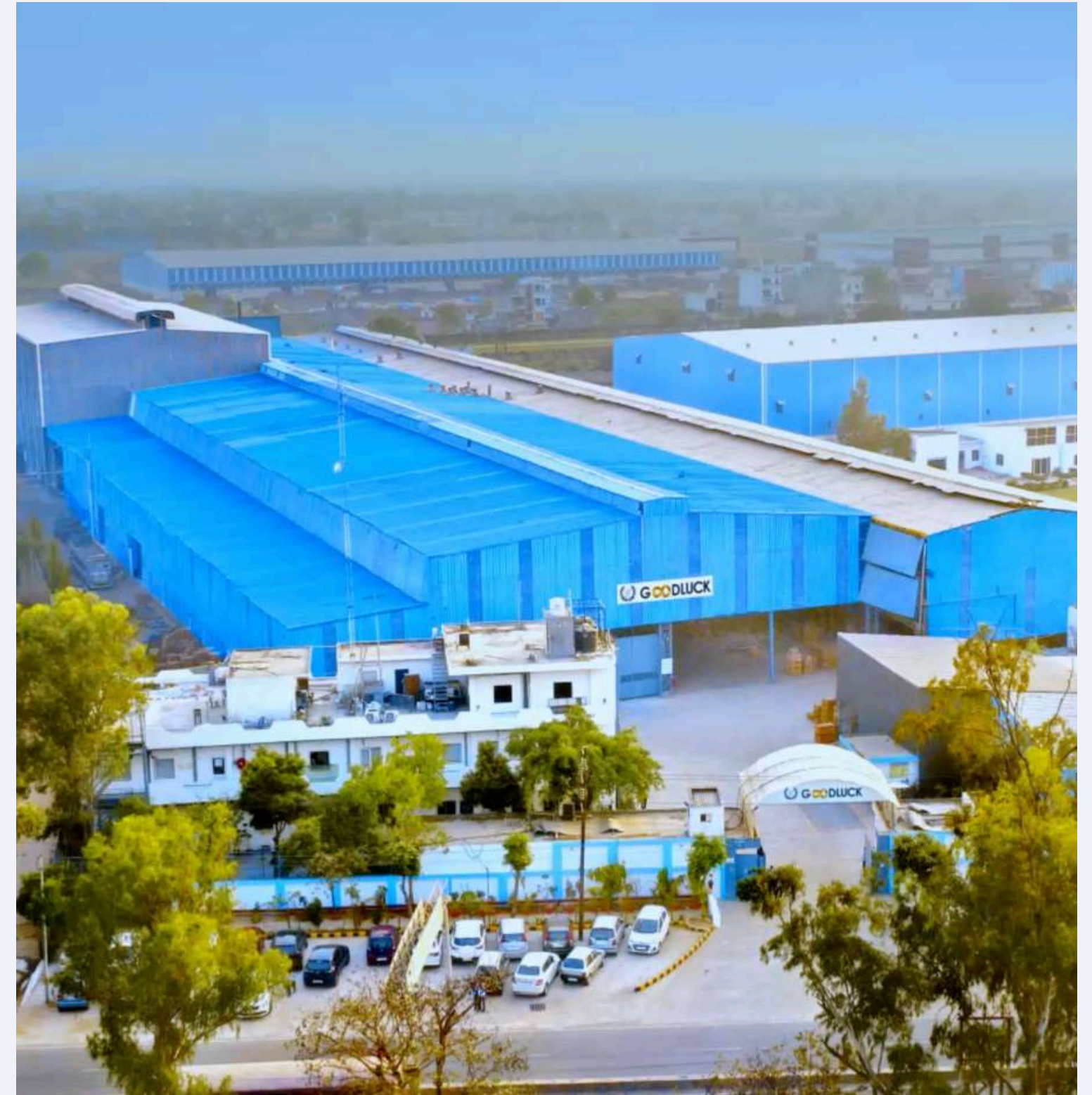

Q3 & 9M FY2025

DISCLAIMER

This presentation has been prepared by Goodluck India Limited (“Goodluck” or the “Company”) solely for information purposes. It does not constitute an offer, recommendation or invitation to purchase or subscribe to any securities. It shall not form the basis or be relied on in connection with any contract or binding commitment whatsoever. No offering of securities of the Company will be made except by means of a statutory offering document containing detailed information about the Company.

This Presentation has been prepared by the Company based on information and data which the Company considers reliable, but the Company makes no representation or warranty, express or implied, whatsoever, and no reliance shall be placed on the truth, accuracy, completeness, fairness and reasonableness of the contents of this Presentation. This Presentation may not be all-inclusive and may not contain all of the information that you may consider material. Any liability with respect to the contents of, or any omission from, this Presentation is expressly excluded.

Certain matters discussed in this Presentation may contain statements regarding the Company’s market opportunity and business prospects that are individually and collectively forward-looking statements. Such forward-looking statements are not guarantees of future performance and are subject to known and unknown risks, uncertainties and assumptions that are difficult to predict. These risks and uncertainties include but are not limited to the performance of the Indian economy and of the economies of various international markets, the performance of the industry in India and worldwide, competition, the company’s ability to successfully implement its strategy, the Company’s future levels of growth and expansion, technological implementation, changes and advancements, changes in revenue, income or cash flows, the Company’s market preferences and its exposure to market risks, as well as other risks. The Company’s actual results, levels of activity, performance or achievements could differ materially and adversely from results expressed in or implied by this Presentation. The Company assumes no obligation to update any forward-looking information contained in this Presentation. Any forward-looking statements and projections made by third parties included in this Presentation are not adopted by the Company, and the Company is not responsible for such third-party statements and projections.



AT A GLANCE

- Led by first-generation techpreneur Mr. Mahesh Chandra Garg (an IIT Roorkee alumni) & supported by three generations of family members - all professionally qualified
- 37+ years of industry presence with a demonstrated track record of innovation & engineering
- 4,50,000 MTPA total capacity
 - 235,000 MTPA capacity - high-margin value-added products
 - 215,000 MTPA - high-volume products
- 6 plants in 2 states (Uttar Pradesh & Gujarat)
- 600+ customers (100+ Countries of exports)
- ISO 9001:2008 certified
- 4000+ employees

KEY BUSINESS SEGMENTS

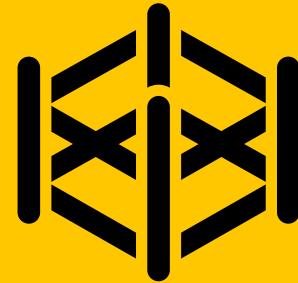

ENGINEERING STRUCTURES & PRECISION FABRICATION

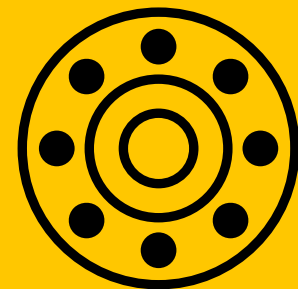

FORGING PRODUCTS

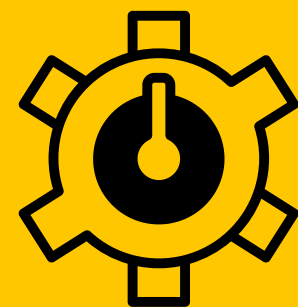

PRECISION PIPES & AUTO TUBES



CR COILS, PIPES & TUBES

- 311567 MT of sales volume (9MFY25)
- Total income of Rs. 2858 crore (9MFY25)*
- EBITDA of Rs. 253 crore (9MFY25)*
- Rs. 2773 crore market cap (06.02.25)

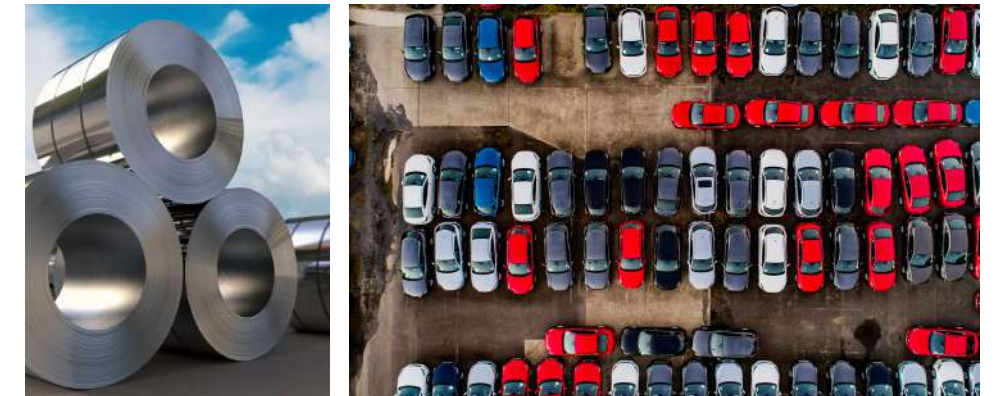
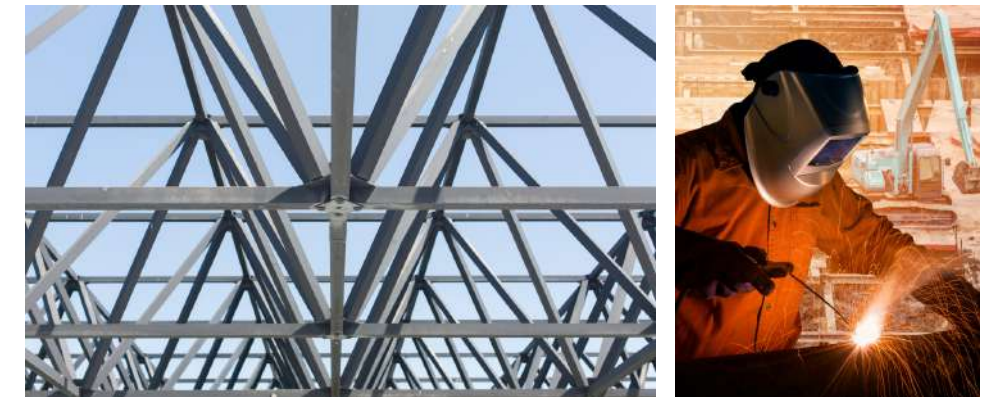

*9MFY2025 Consolidated



- **Hands-on involvement of the family's three generations backed by robust professional management across business verticals**
- Fast evolving from manufacturing steel products to becoming an Engineering Solutions provider
- **Strategically focused on High Margin Value Added Products and high-growth sectors like Auto, Solar, Railways and Defence**
- Catering to Marquee Clients across the world
- **Own R&D set-up with state-of-the-art NABL (ISO / IEC17025) accredited Quality Testing Lab**
- Consistent financial performance with margin improvement

**ESTABLISHED MANUFACTURER OF
PRECISION-ENGINEERED STEEL PRODUCTS
FOR HIGH-GROWTH SECTORS.**

OUR JOURNEY

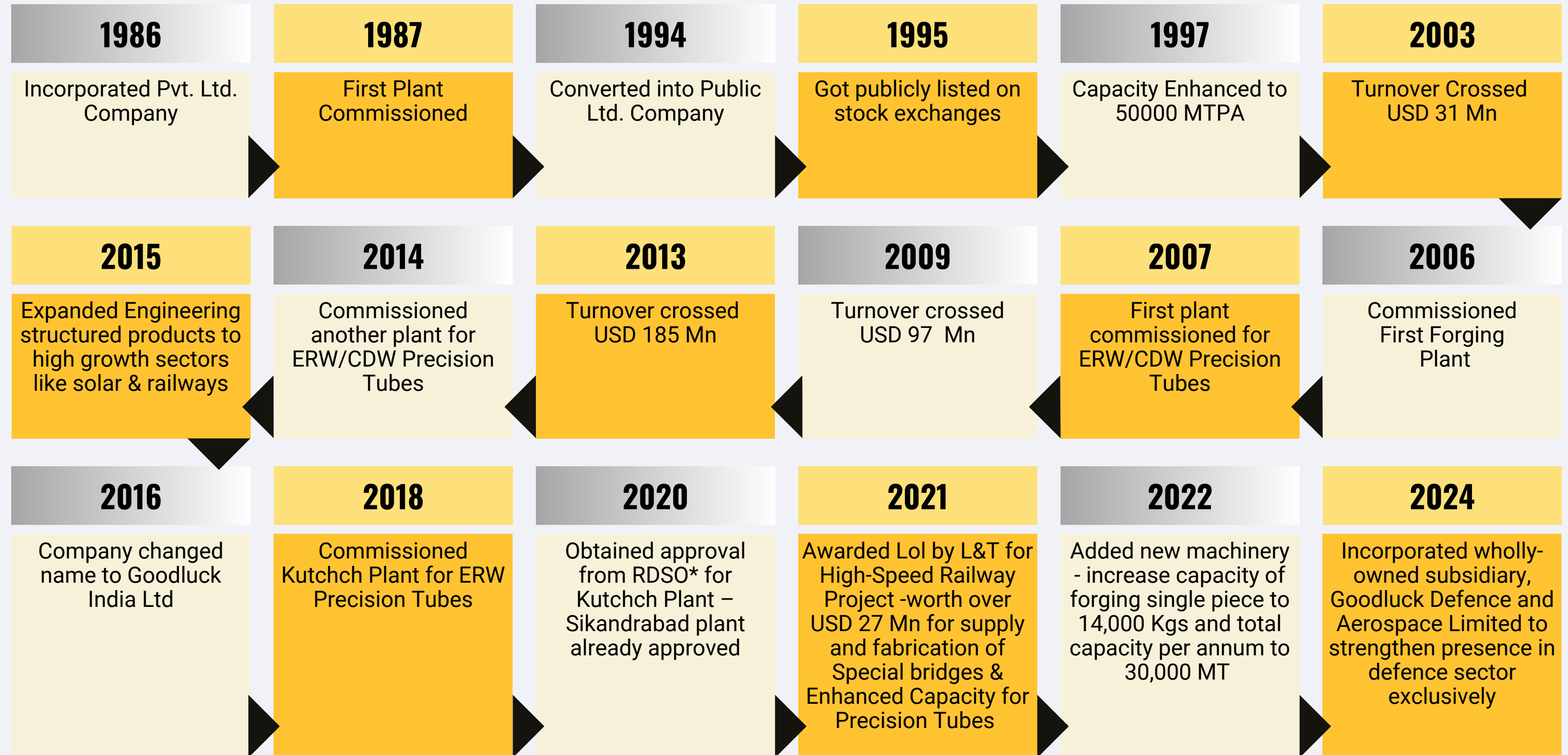



MAHESH CHANDRA GARG
CHAIRPERSON

- Graduated in 1967 from the prestigious - Indian Institute of Technology, Roorkee
- 5+ decades of experience across the world
- A visionary with exceptional management skills



RAMESH CHANDRA GARG
WHOLE TIME DIRECTOR

- Engineer in the field of mining from highly acclaimed ISM – Dhanbad
- Fine experience in the Coal industry
- Possesses more than five decades of experience
- Great motivator and an excellent team leader



NITIN GARG
WHOLE TIME DIRECTOR

- Qualified Engineer and M.B.A. from Narsee Monjee Institute of Management
- Worked with Yamaha Motors and Honda Motors
- Looking after the production process



RAM AGARWAL
CHIEF EXECUTIVE OFFICER

- Qualified Engineer and completed his graduation in 1990
- 33 years experience in steel industries
- Handled CR, Structure projects and Maintains equivalent exposure in the field of sales and marketing

HANDS-ON MANAGEMENT TEAM





MANISH GARG
CHIEF OPERATING OFFICER

- Qualified Engineer from Indian Institute of Technology
- Handling overall Export Business since the last 31 years



SHYAM AGARWAL
CHIEF OPERATING OFFICER

- Qualified Engineer
- Has more than 30 years of experience in the steel Industry especially of the forging industry



SANJAY BANSAL
CHIEF FINANCIAL OFFICER

- Qualified Chartered Accountant with over 30 years of experience across the company's finance activities, including business planning, budgeting, forecasting, taxation, and negotiations.
- Served in JP Group, DS Group and Dr. Rajaram Jaipuria Group



ABHISHEK AGRAWAL
COMPANY SECRETARY

- Qualified Company Secretary with around 16 years of experience across Corporate Secretarial Functions
- Current responsibilities include Strategic Planning, Legal Affairs, Compliances and investor relations

HANDS-ON MANAGEMENT TEAM



MANUFACTURING PROWESS

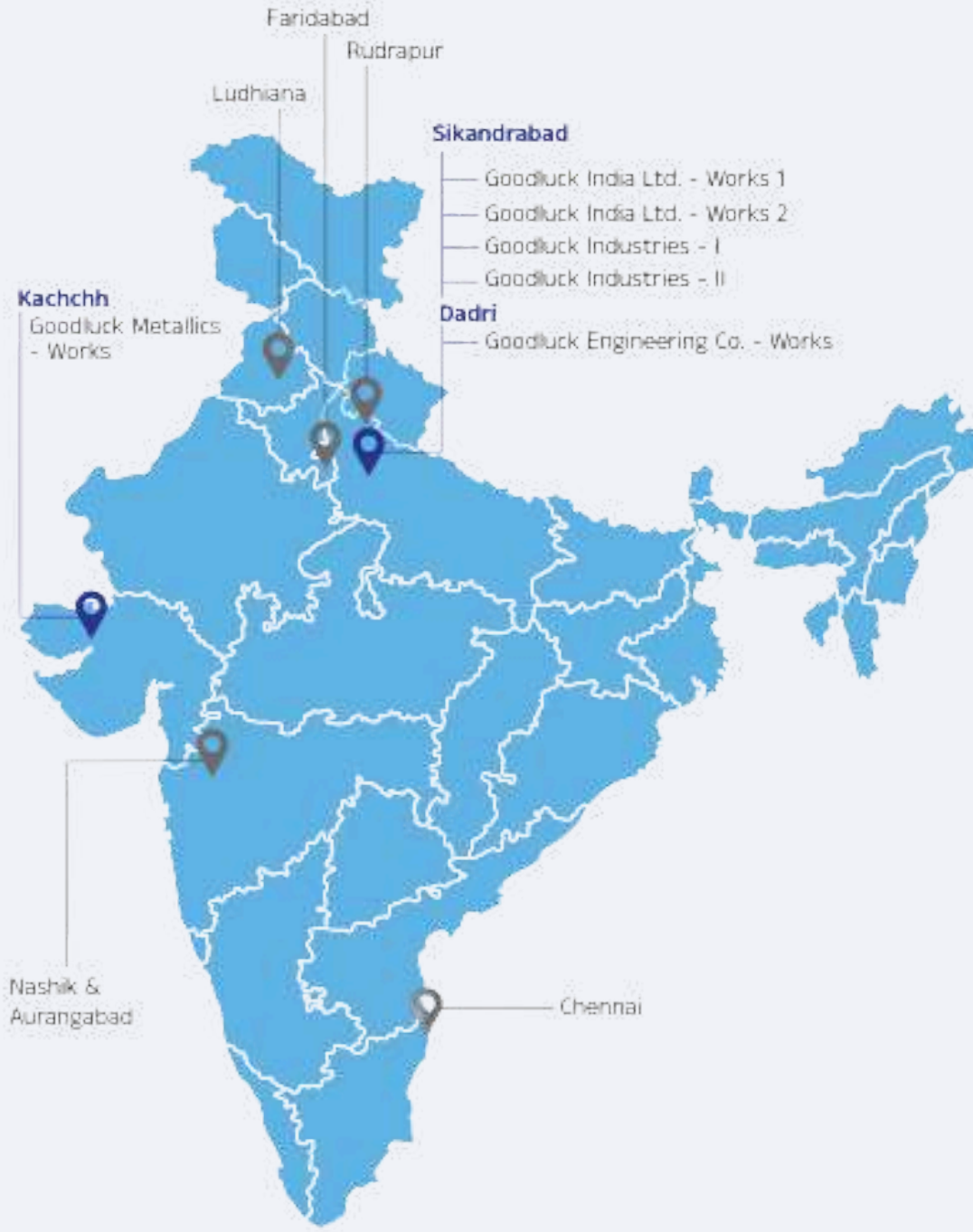
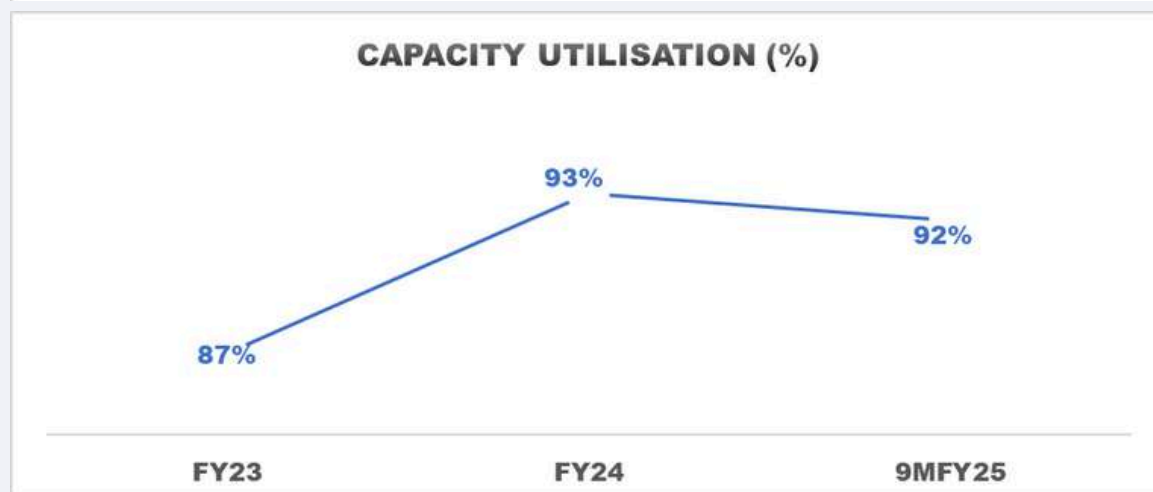
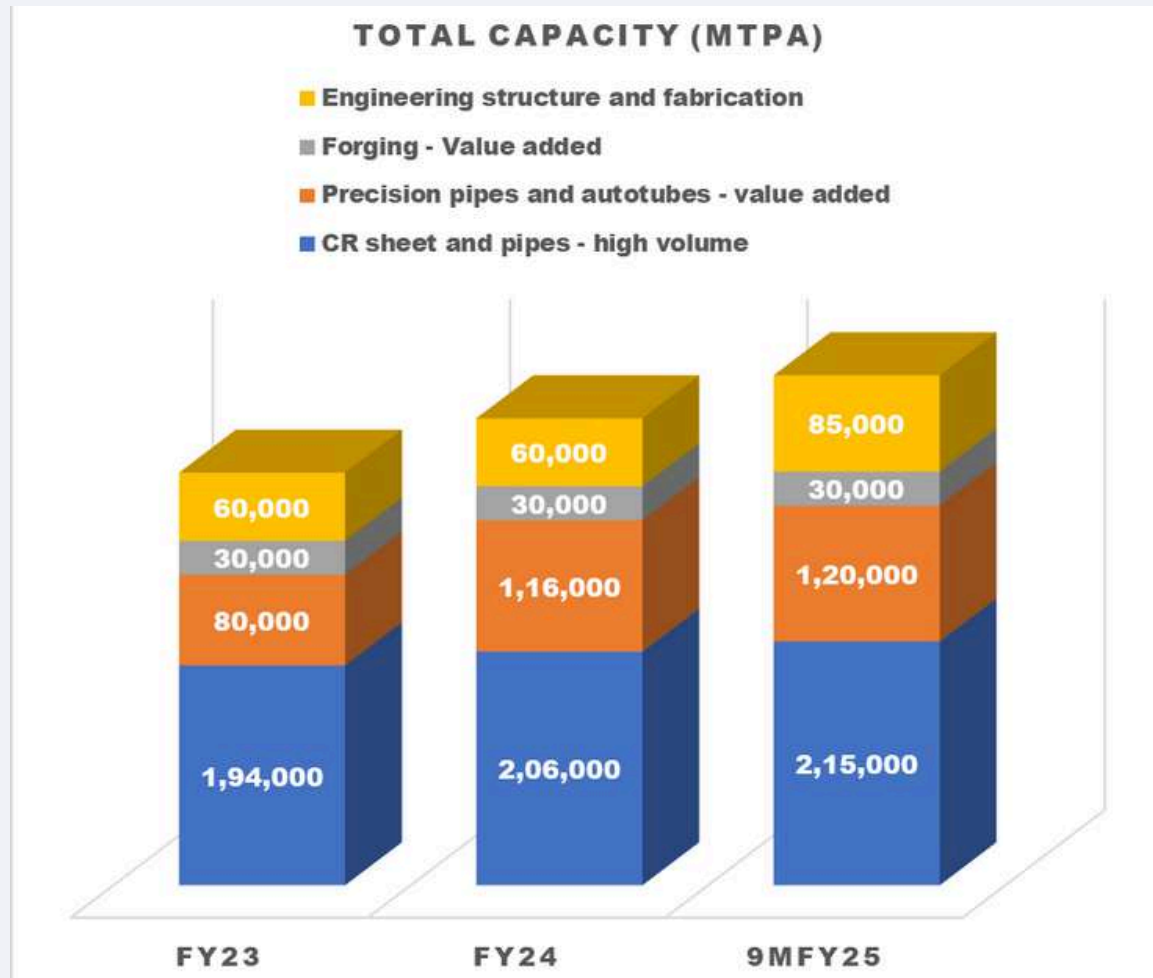

Manufacturing Plant
 Warehouse



ESTEEMED CLIENTELE

Auto Tubes	Global		Domestic						
Forgings	Global		Domestic						

Engineering Structures Domestic		



CLIENT APPROVALS

GLOBAL PRESENCE

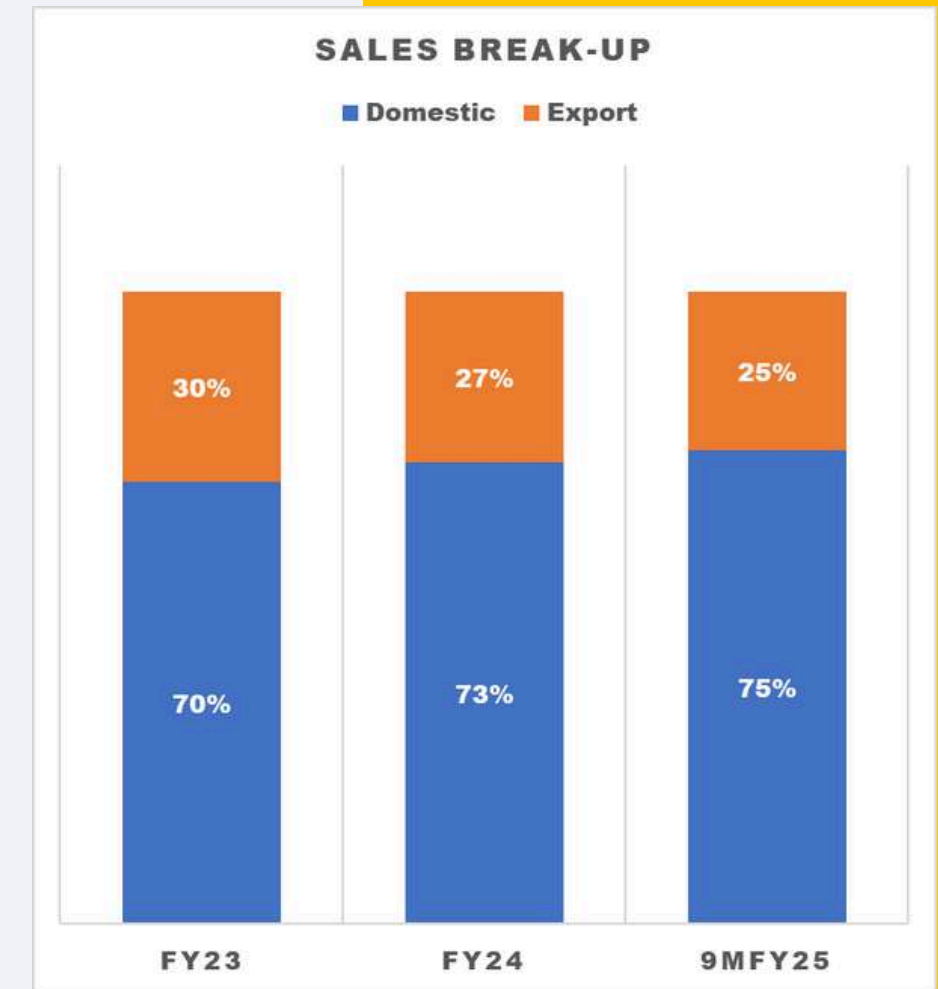

QUALITY CERTIFICATIONS



BUSINESS SEGMENTS

Engineering structure and fabrication

21%

Forging
15%

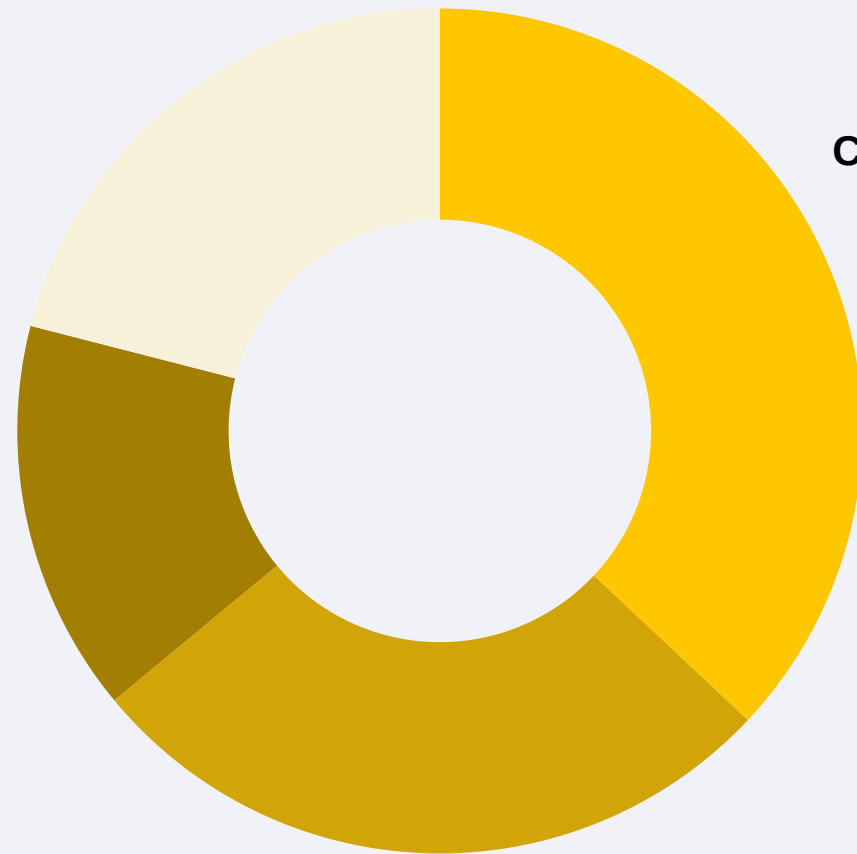

CR sheet and pipes
37%

Precision pipes and auto tubes
27%

FY24

Engineering structure and fabrication

23%

Forging
15%

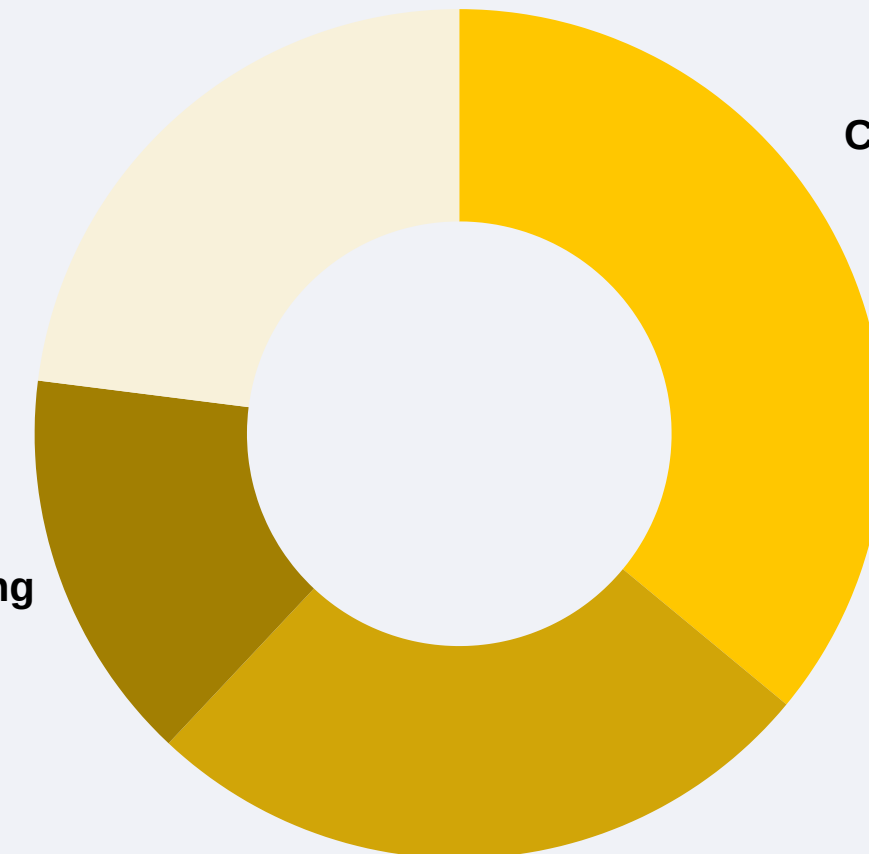

CR sheet and pipes
36%

Precision pipes and auto tubes
26%

9MFY25



ENGINEERING STRUCTURES & PRECISION FABRICATION



Products & Services Offered

- Railway, road, Bridges and Girders
- Structures for Roads & Highways
- Primary & Secondary Structures for Boilers & Turbine Generators
- Launching Girders For Steel & Concrete Girders Building Structures
- Technology Structures

New Areas of Growth and Drivers

- Special Formwork for Elevated corridors
- Special Formwork for Tunnel Boring Machine for High-Speed Rail
- Station Buildings for High-Speed Bullet Train
- Super Critical Bridges for High-Speed Bullet Train
- Smart City Structures
- Car Port and Solar Parks – Design Engineering & Supply. • Architectural Structures in Wire-drawn Bridges

Marquee Clients

- Indian Railways
- ABB
- L&T
- Reliance Industries
- GMR
- ISGEC
- Sterling & Wilson
- Alstom
- PowerGrid
- NTPC
- Toshiba
- TRF
- EIL
- NPCIL
- MHSR

End User Industries

- Roads & Highways
- Railways
- Telecom
- Boiler and Turbine Generators
- Steel & Concrete Girders
- Building Structure
- Solar Energy



**RIDING ON THE BULLET
TRAIN OPPORTUNITY**



FORGINGS



Products & Services Offered

- Defence products
- Aerospace parts
- Forged flanges
- Gear rings
- Gear shanks
- Forged shafts
- Blind & tube sheets
- Socket welding flanges
- Slip on flanges

Marquee Clients

- DRDO
- ISRO
- HAL
- GE Oil & Gas
- Allied Group
- Saint-Gobain
- BPCL
- Indian Oil
- BHEL
- RIL
- L&T

End User Industries

- Aerospace
- Defence
- Automobile
- Construction & Earth Moving Equipment
- Nuclear Power
- Oil & Gas
- Petrochemical
- Fertiliser
- General Engineering

New Areas of Growth and Drivers

- Stainless Steel, Duplex, Carbon, and alloy Steel Forgings and flanges
- Focused on manufacturing forged products, providing end-to-end solutions

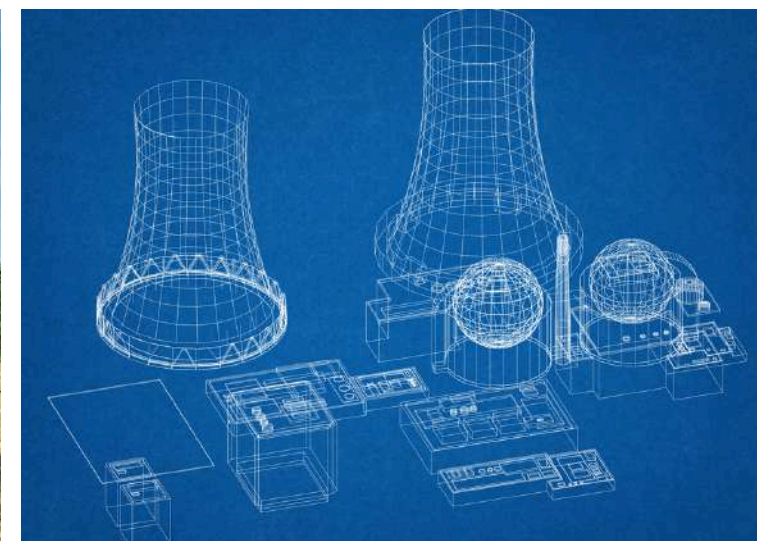
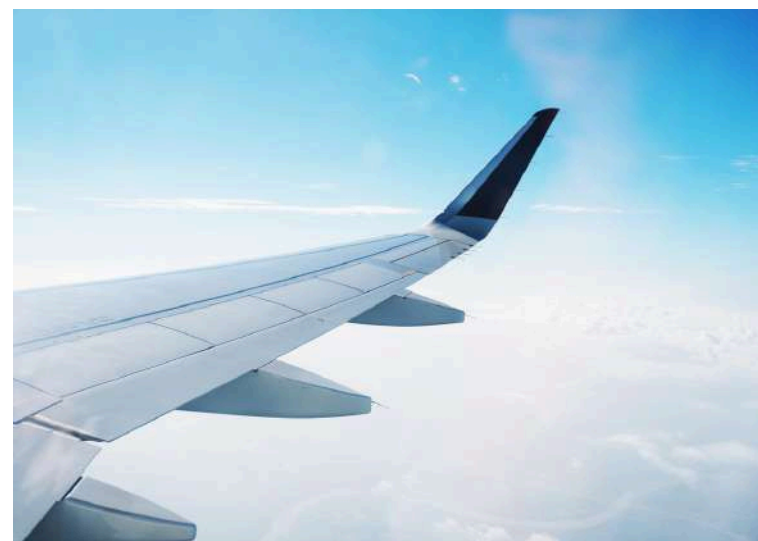

AEROSPACE & DEFENCE - THE FUTURE GROWTH DRIVERS FOR FORGINGS

Suppliers to some of the biggest names across Indian **Aerospace** and **Defence** value-chain

Govt. / PSUs



Hindustan Aeronautics Limited



Defence Research and Development Organisation



Indian Space Research Organisation



OFB – Heavy Vehicles Factor Avadi



OFB – Ordnance Factory Medak



Bharat Earth Movers Limited



Mazagon Dock Shipbuilders Ltd.

MSMEs / Tier – 2 &3



Walchandnagar Industries Limited



SriVenkateswara Aerospace Pvt. Ltd.



SMRJ Engg Pvt. Ltd.



Brahmos Aerospace



L&T Defence



Godrej Aerospace

Suppliers to prestigious Defence programs

- Pralay Missiles
- HAL – HTFE Program
- Brahmos Missiles
- Pinaka Rockets & Indigenous Rocket Launcher
- K9 Vajra – Tracked Howitzer
- Talwar Class Frigates

Defence contribution ~2%

PRECISION PIPES AND AUTO TUBES



Products & Services Offered

- CDW Tubes
- ERW Tubes
- Engineering Tubes
- Boiler Tubes

New Areas of Growth and Drivers

- Consistent quality products for domestic and foreign companies.
- Repeat orders have increased over the years, signifying customer loyalty.
- High-margin products
- Key export revenue contributor.

Marquee Clients

- Volkswagen
- Audi
- BMW,
- Mercedes
- Skoda
- Renault
- GM
- Ashok Leyland
- TVS
- Bajaj
- Gabriel
- ISGEC
- Talbros
- Mahindra
- Tata Motors

End User Industries

- Aerospace
- Defence
- Automobile and Railways
- Construction & Earth Moving Equipment
- Fertilisers
- General Engineering
- Heat Exchanger Nuclear Power
- Oil & Gas and Petrochemical
- Pressure Vessels
- Thermal Power Valves
- Wind Energy

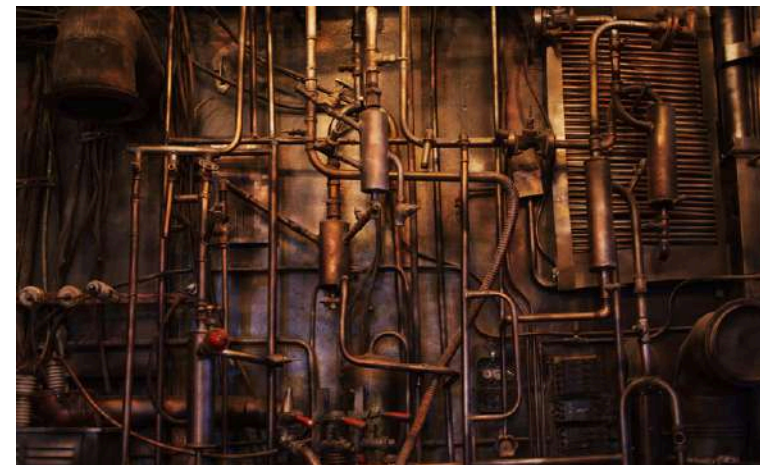

CR COILS, PIPES AND TUBES

Products & Services Offered

- Cold Rolled Coils and Sheets
- Corrugated Sheets
- Hollow Sections (square, rectangle, round hollow)
- GI Pipes

New Areas of Growth and Drivers

- Product thickness
- High tensile strength
- Long service life
- Higher efficiency.
- GLIN supplies to only OEMs and government projects.

Marquee Clients

- Public sector OEMs
- Private sector OEMs
- Central government
- State government

End User Industries

- Railways
- Road bridges
- Support structures



KEY RECENT DEVELOPMENTS (Q3FY25)

- Successfully commenced commercial production of its Hydraulic Tubes manufacturing plant at Sikandarabad Industrial Area from 1st January, 2025.
- Announced plans to set up a new facility, within Goodluck India Limited's subsidiary company, to cater to the extensive needs of the defence and aerospace industry. The plant would have a capacity of 1,50,000 shells and the cost of investment would be ~Rs.216.50 crore funded by debt and equity. Trial production is expected to commence from Q1FY26.





FINANCIAL PERFORMANCE



FINANCIAL PERFORMANCE (Sequential QoQ)

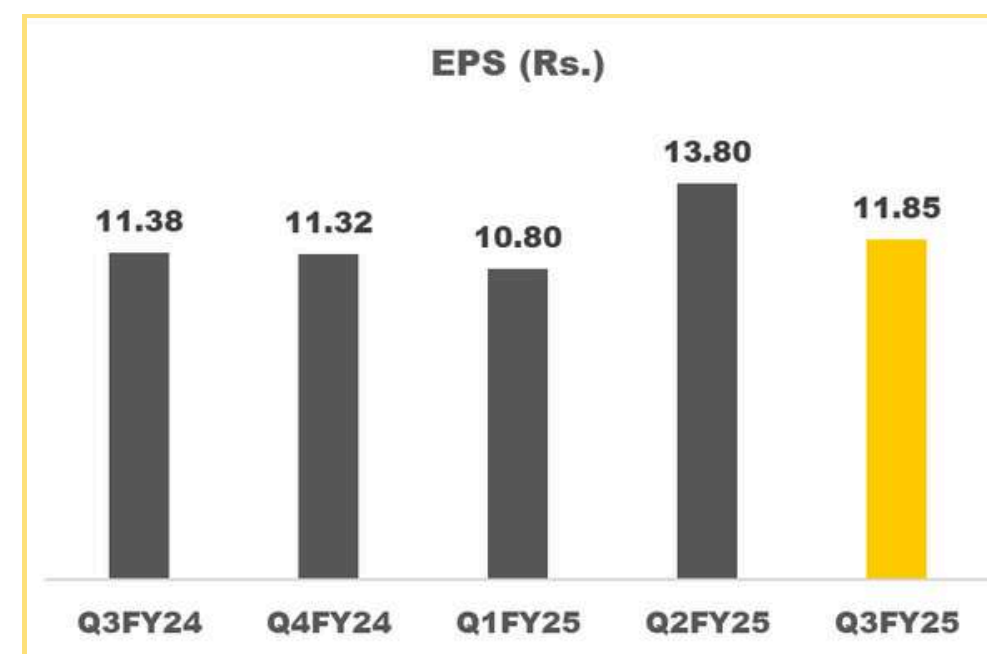
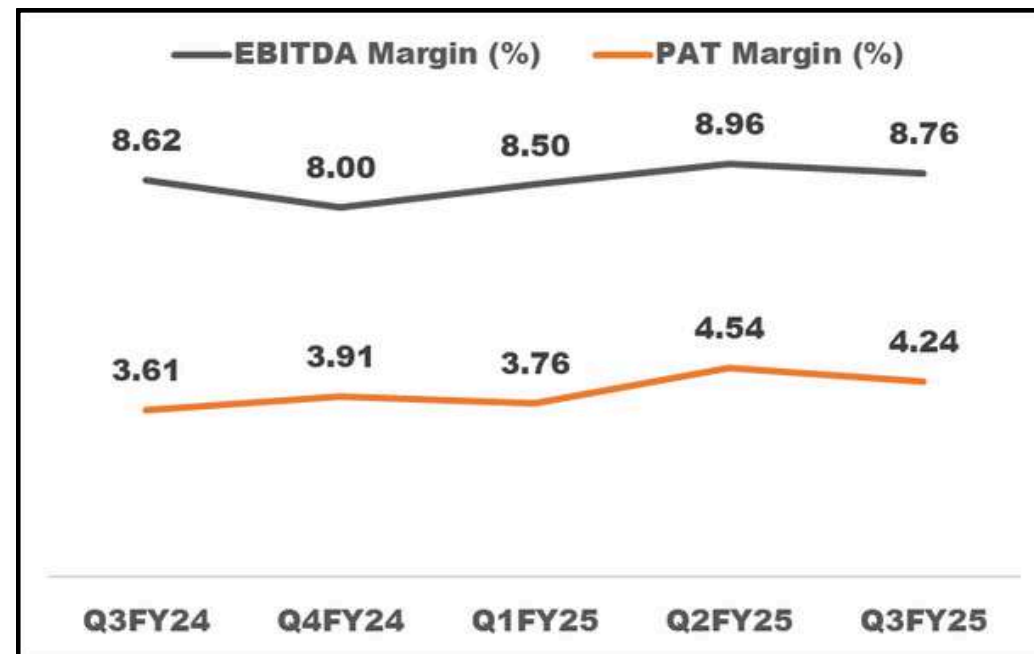
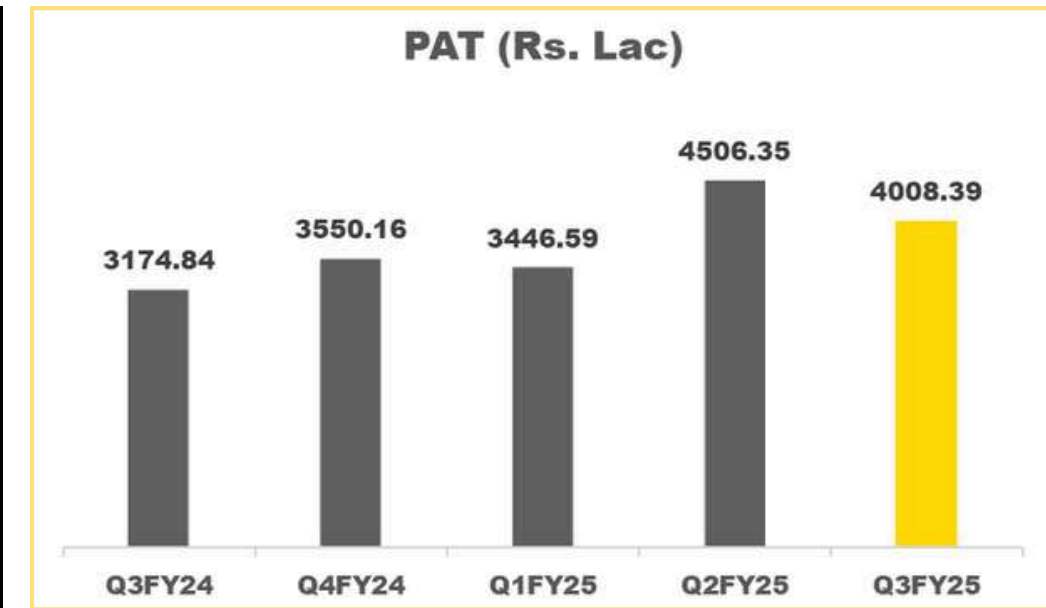
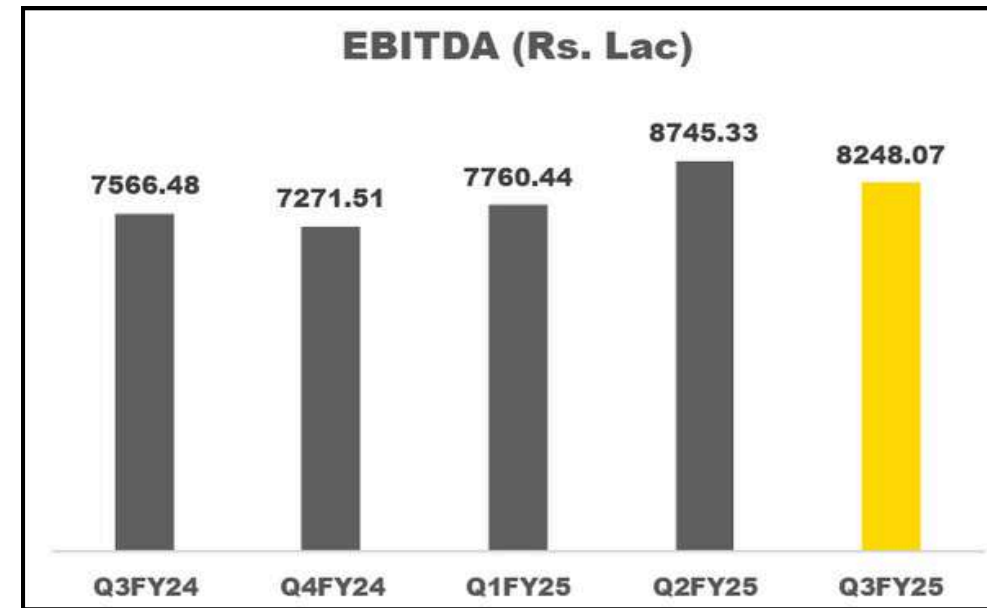
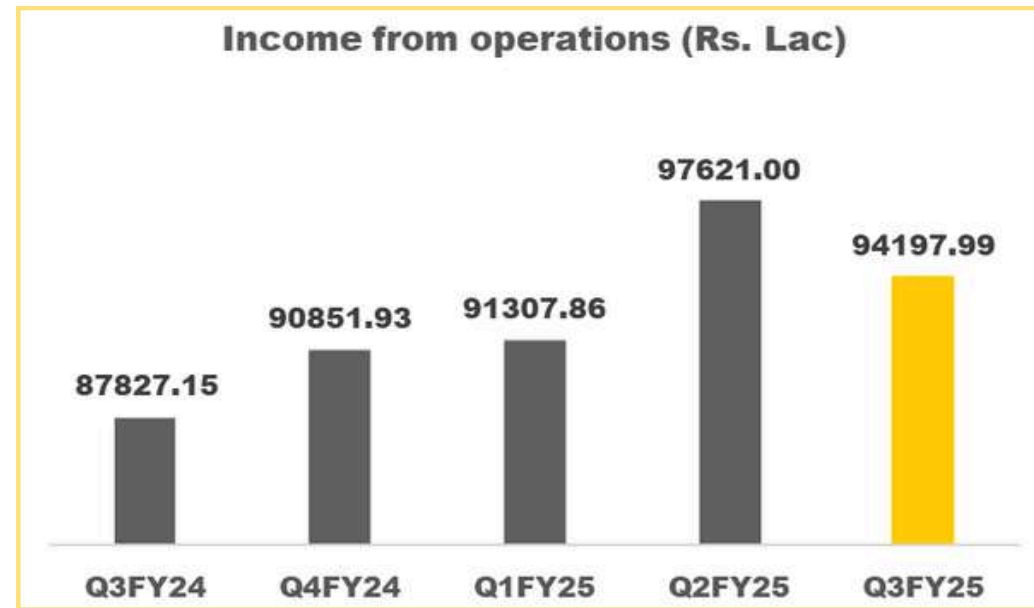

All data related to the financial performance section of the investor presentation are on a standalone basis



FINANCIAL PERFORMANCE (QoQ)

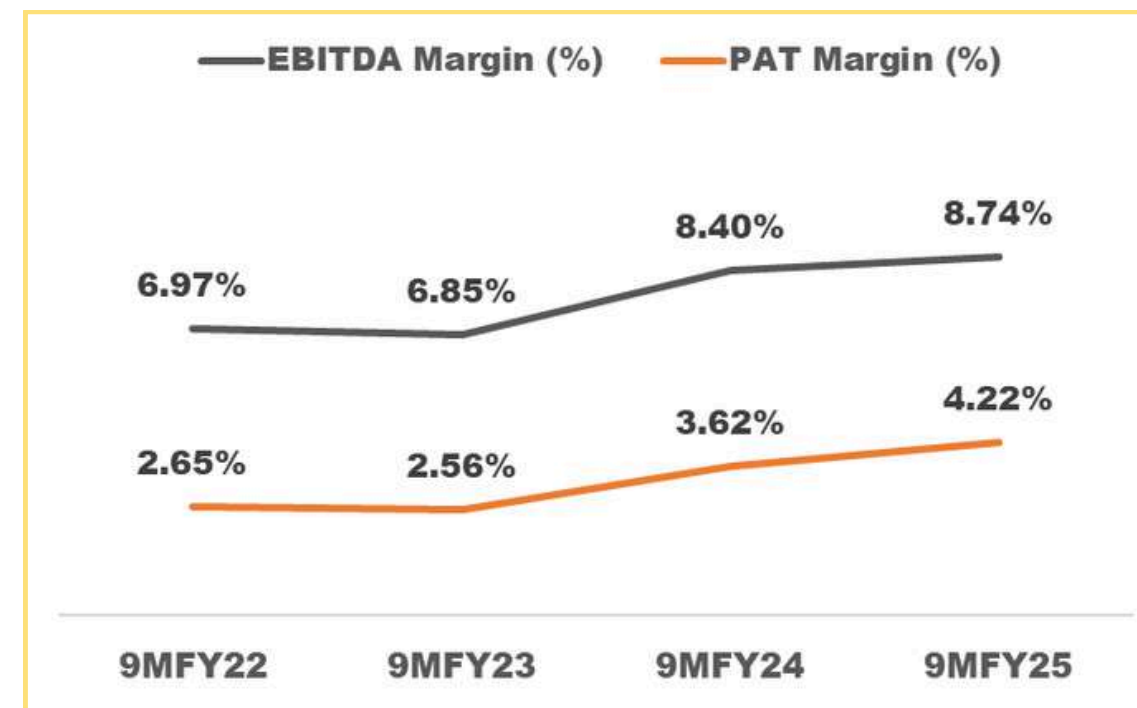
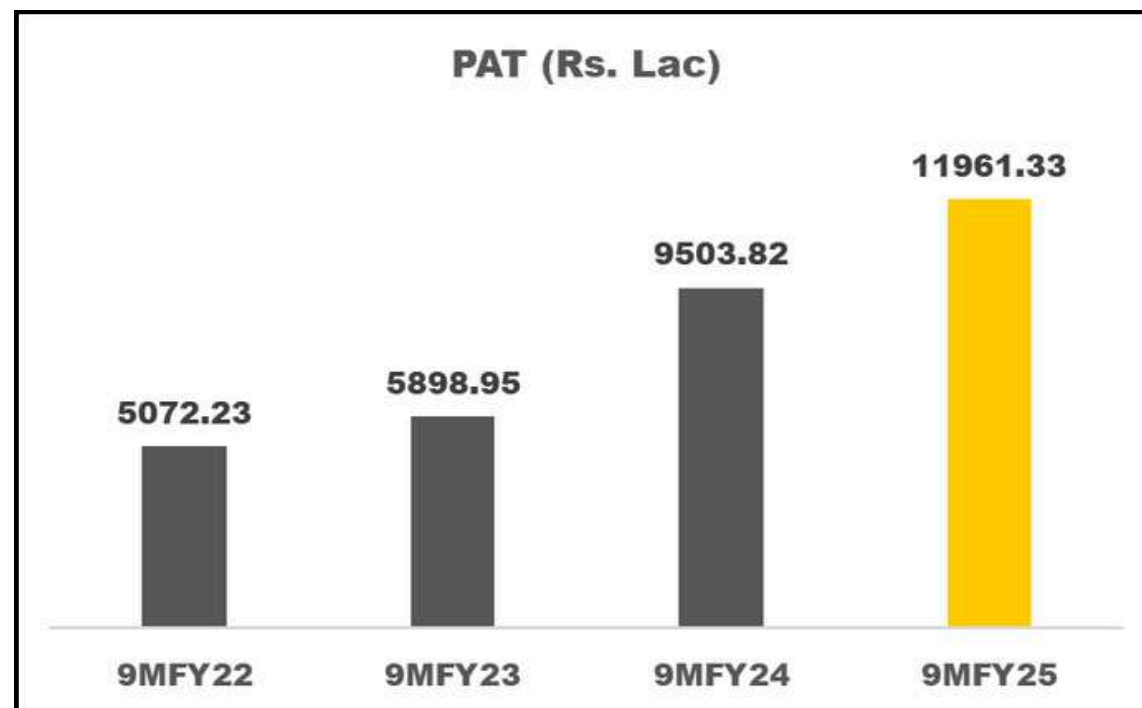
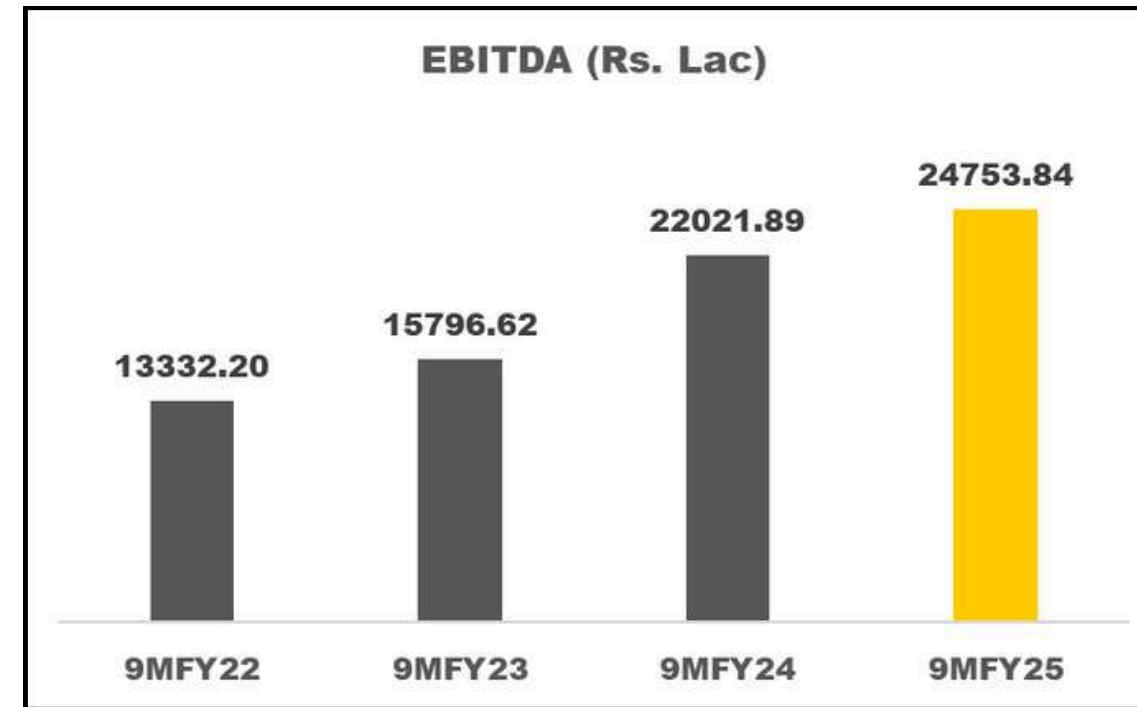
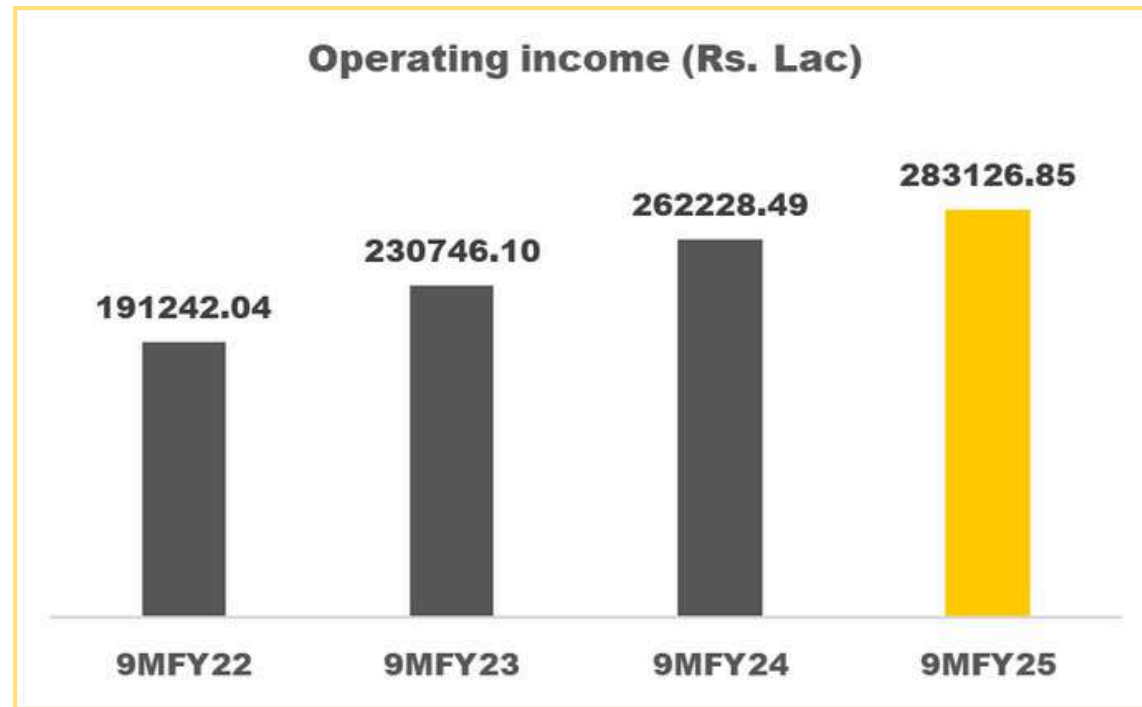

FINANCIAL PERFORMANCE (YoY)

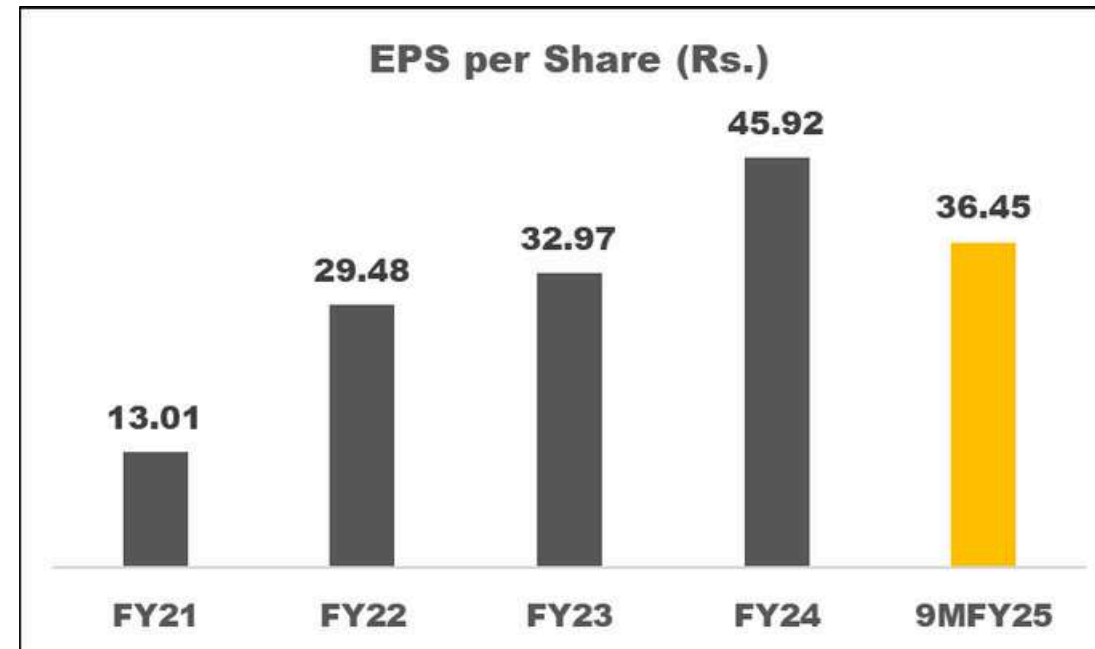
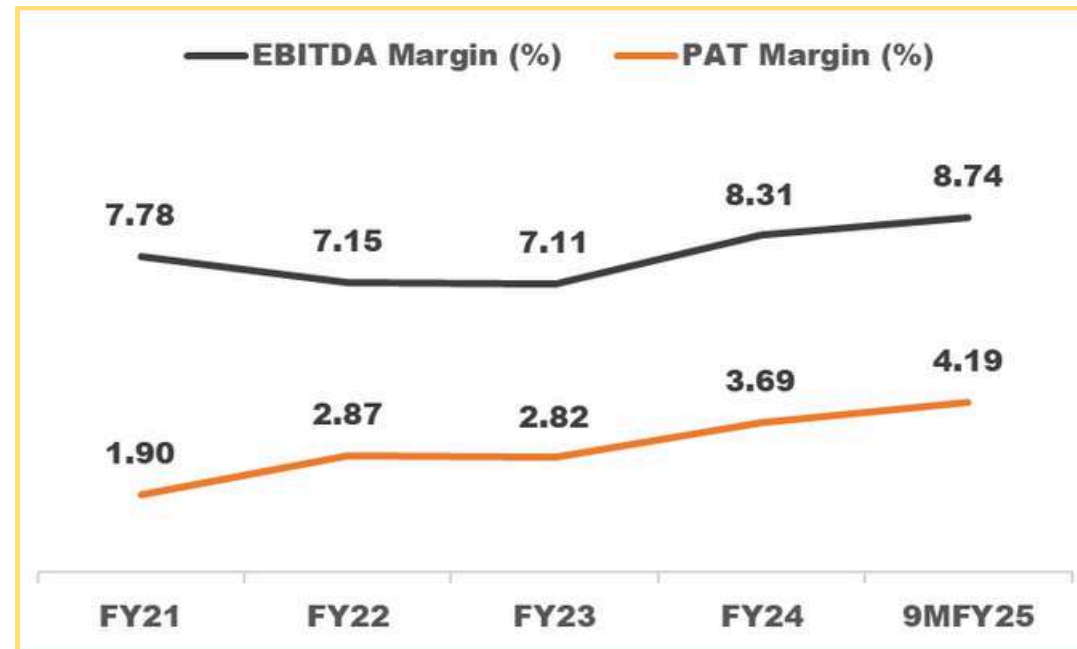
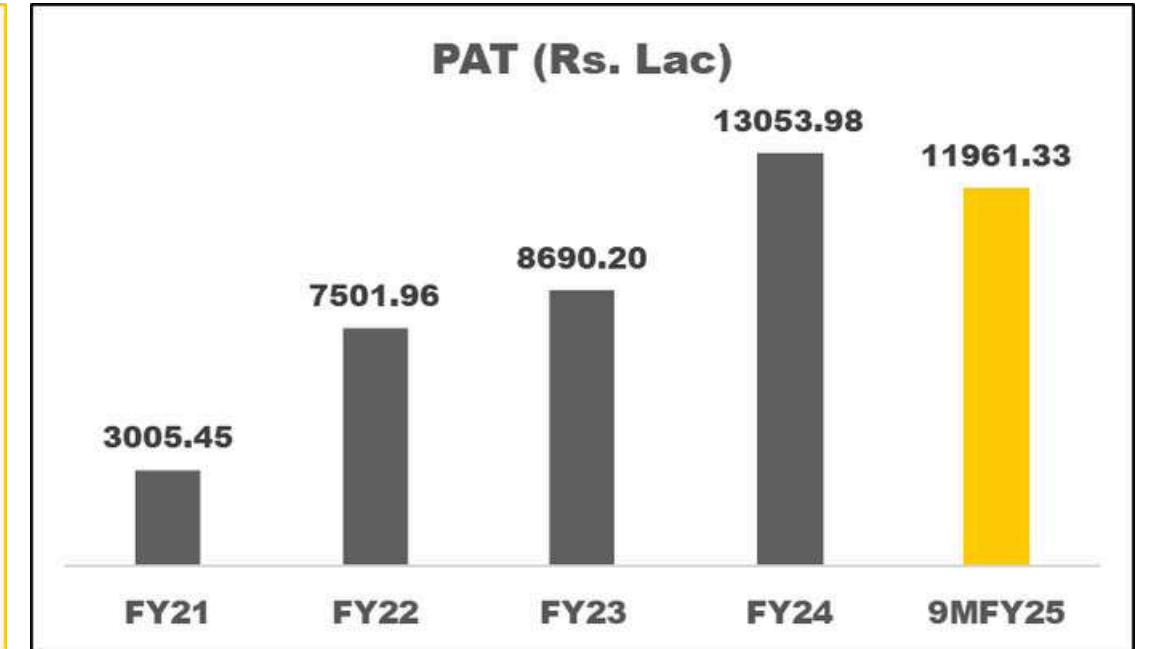
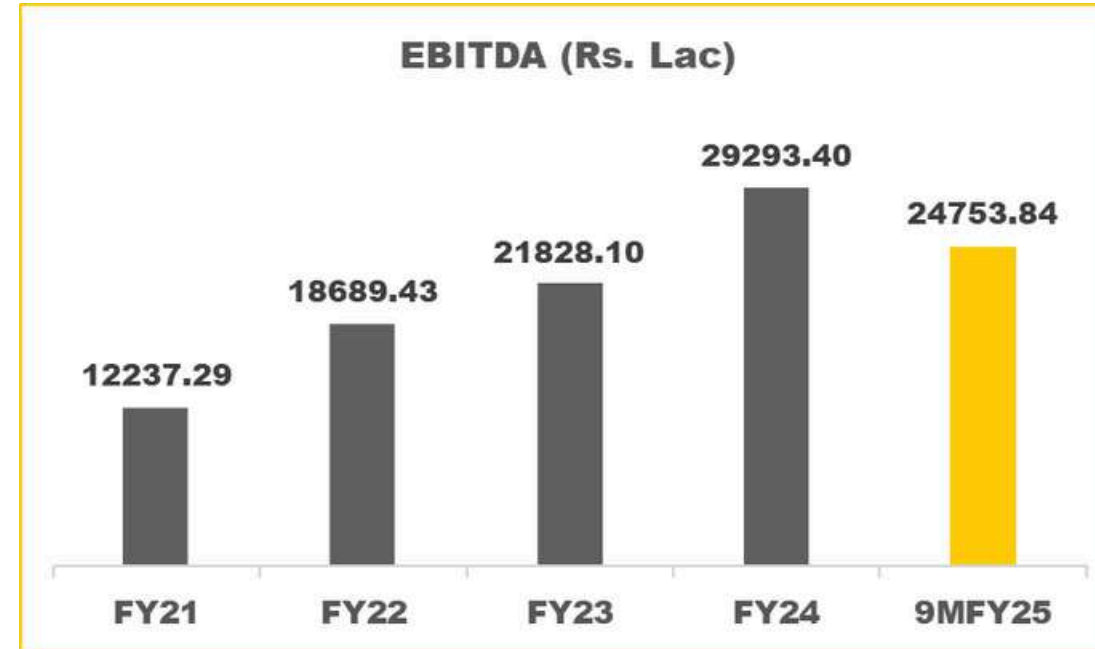
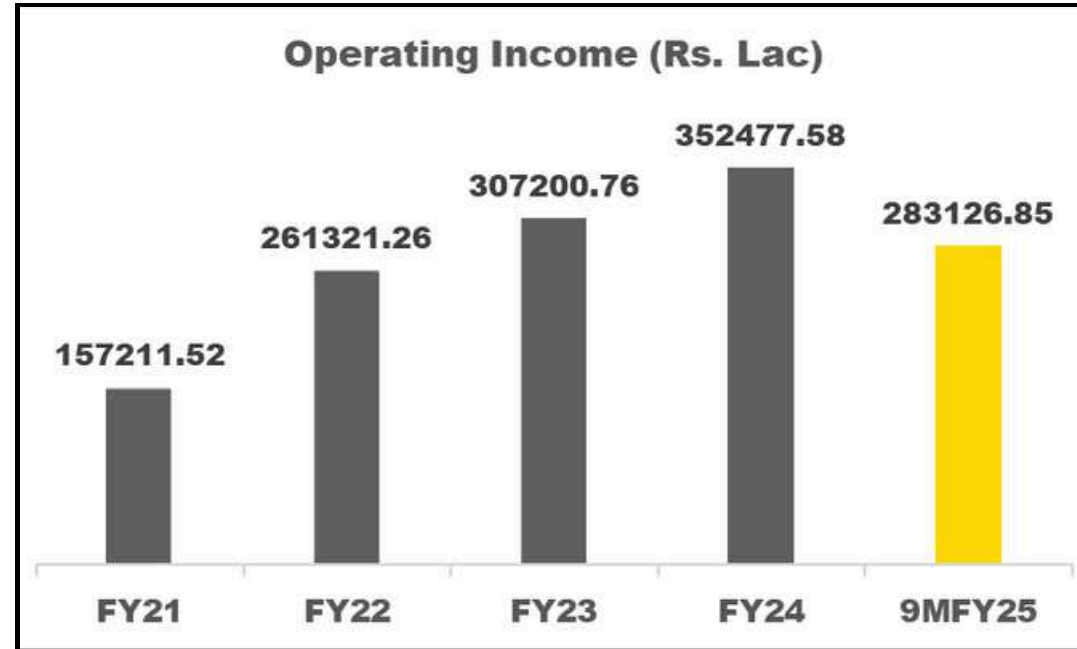

RESPONSIBLE CORPORATE CITIZEN



- Actively supports causes of healthcare, education and environment through sustained CSR initiatives
- Culture as an employer is full of transparency, open doors, and consistent upskilling focus
- Uninterrupted focus on seeding a green culture and sustainability agenda by in ticking the three yogis



WRAPPING UP

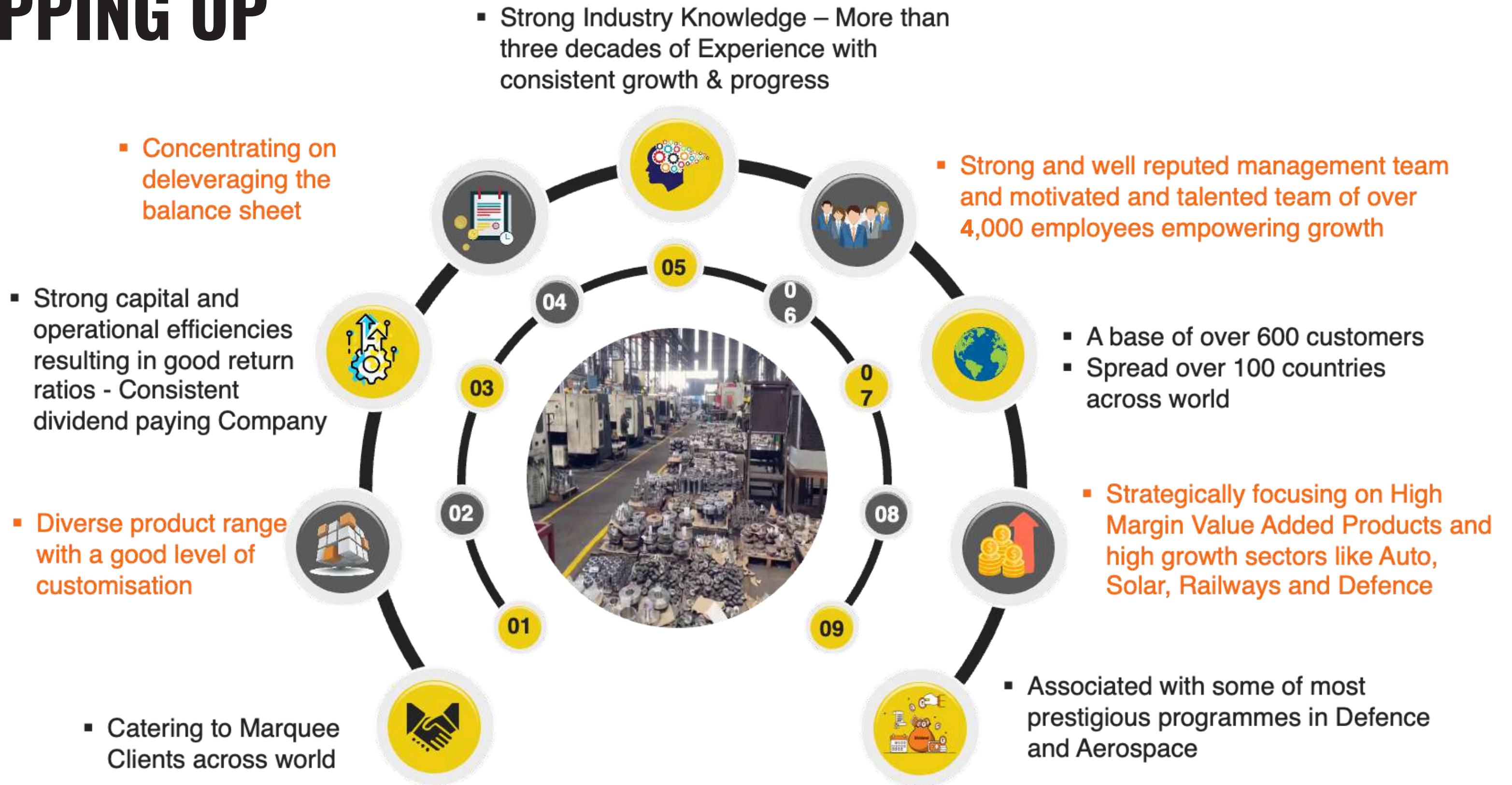

From manufacturing steel products to becoming an Engineering Solutions provider



Corporate Office :-

GOODLUCK INDIA LIMITED

CIN No. : L74899DL1986PLC050910

Good Luck House, II F, 166-167, Nehru Nagar 2,
Ambedkar Road, Ghaziabad - 201001, Uttar
Pradesh, India

goodluck@goodluckindia.com

CONTACT US

Regd. Office : (Goodluck India Ltd)

509, Arunachal Building, Barakhamba Road,
Connaught Place, -2pxNew Delhi - 110001 (INDIA)

CIN No. : L74899DL1986PLC050910

Good Luck Industries (Works)

A-51, Industrial Area, Sikandrabad,
Distt.-Bulandshahr - 203205 (U.P.) INDIA

Goodluck Metallics (Works)

Survey No. 495,497 to 502, Bachau Sikra Road,
Village-Sikra, T A Bachau, Gujarat - 370140, INDIA

Goodluck India Limited. (Works)

A-42/45, Industrial Area, Sikandrabad,
Distt. Bulandshahr - 203205 (U.P.) INDIA

Good Luck Industries-II (Works)

A-59, Industrial Area, Sikandrabad,
Distt.-Bulandshahr - 203205 (U.P.) INDIA

Goodluck India Limited. (Works II)

D-2/3/4, Industrial Area, Sikandrabad,
Distt. Bulandshahr - 203205 (U.P.) INDIA

Good Luck Engineering (Works)

Khasra No. 2839, Gram Dhoom Manikpur, G.T. Road
, Gautam Budh Nagar, Dadri, (U.P.) INDIA

THANK YOU